

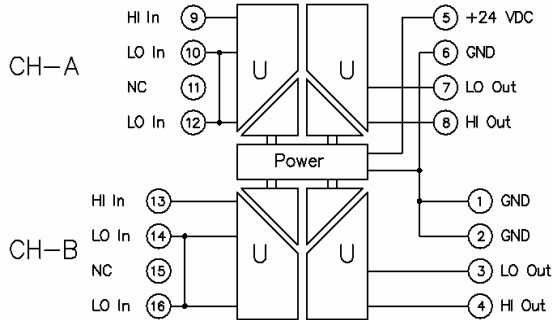

Description

The Signal Conditioning Module **PI335 Dual ISC** consists of two independent isolating amplifier channels. The inputs can be configured for bipolar voltage ranges of 10V, 20V, 50V, 100V and 200V. The output voltage range is always $\pm 10V$.

Signal input, signal output and power supply voltage are isolated - see Block diagram / Pin number assignment below:



Configuration

For configuration changes, you have to unlock and open the enclosure (see below)



Take protective measures against electrostatic discharge !

Set the jumpers and switches according the configuration table on the right



Jumpers CH-A and CH-B are on the main board.
Switches CH-A and CH-B are on the piggyback board.

Range	Jumper	Switch
		1 2 3 4
10V		
20V		
50V		
100V		
200V		

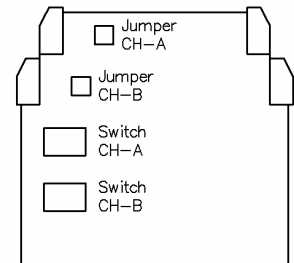

Technical Data

Input voltage ranges:	$\pm 10V, \pm 20V, \pm 50V, \pm 100V, \pm 200V$	Transmission error:	< 0.1% of end value
Input resistance:	100kOhm 200kOhm @ 200V range	Temperature coefficient:	< 80ppm / °C
Max. input voltage:	150V steady state 250V @ 200V range	Cut-off frequency:	50kHz (-3dB)
Output voltage:	$\pm 10V$ (Load > 2kOhm)	Ambient temperature range:	0..50°C (32..122°F)
Isolation Voltage:	500V Input to GND 100V Output to GND	Dimensions:	114 x 100 x 22.5 mm
Power supply voltage:	20..30V DC	EMC:	according with EN 50082-1(-2)
Power consumption:	app. 3W @ 24V (1.5W per ch.)	Electrostatic discharge:	8 kV - in air EN 61000-4-2
		Fast transient burst:	2kV / 5kHz EN 61000-4-4
		Surge voltage:	2kV / 420Ohm EN 61000-4-5

Mounting

The modules should be mounted in vertical position, with a free space of at least 15mm to the next device, to obtain a adequate cooling.



Remarks

A possible shield wire on the input side should be connected to the "Lo In" clamp.

A possible shield wire on the output side should be connected to the "GND" clamp (Ground potential of the 24V power-supply voltage).